

# STD-65

## Absolute Position Sensor

The **STD-65** is a contact-less optical reflective absolute position sensor. It has Integrated dual sensing heads and advanced processing, which gives it a very high precision over a low profile and redundant core.

The **STD-65** support SSi & BiSS-C interfaces.

The wide assembly tolerance of the **STD-65** makes it easy to install and align, its plug and-play approach makes it simple to design into any application.

High precision single turn, optical reflective absolute position sensor

- Contact less
- Dual core, redundant - Duplus core technology
- Low profile
- High resolution
- High accuracy



Mechanical		
OD stator	mm	65
ID rotor	mm	27
Height	mm	7
Rotor moment of inertia	Kgm <sup>2</sup>	< 6 x 10 <sup>-8</sup>
Permissible radial run-out	mm	± 0.4
Rotor / Stator air gap	mm	1.75 ± 0.5
Weight	gr	40

Characteristic's		
Resolution	bit	18 - 22
Accuracy [INL]	mdeg	± 2
Repeatability	count	± 1
Data latency	µsec	20
Startup time	msec	20
Current consumption	mA	130
Power supply	VDC	5 ± 5%
Rotation speed, max	RPM	4,000
Sensor position bandwidth	KHz	40 (SSi) / 65 (BiSS-C)
Thermal drift		None

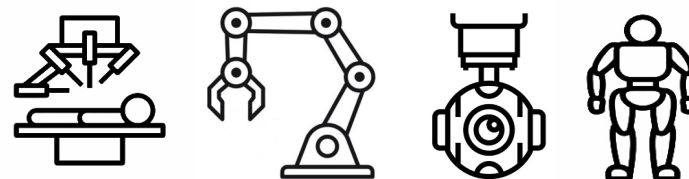

### Environment Condition's

Temperature, operational	-40 to 85 C° <sup>1</sup>
Humidity	95% relative humidity, Non condensing, IEC 60068-2-78
IP rating	IP 40 , (enclosed)
Shock	1000 m/s <sup>2</sup> , 6 ms, ½ sine, 3 axes
Vibration	100 m/s <sup>2</sup> max @ 55 Hz to 2000 Hz, 3 axes
Pressure	600 bar max
Vacuum	1.0 × 10 <sup>-7</sup> Pa
Magnetic field	Immune
EMC compliance	IEC 61326-1
Environmental compliance	RoHS, REACH

### Storage and Handling



Stator is ESD-sensitive and must be handled with care.

Avoid touching the electronic circuitry, wiring, or sensor surfaces unless you are using proper ESD protection and are within an ESD-controlled environment.

### Storage Condition's

Temperature, Storage	-45 to 105 C°
Humidity	70 % relative humidity, Non condensing,

Notes :

<sup>1</sup> Extended temperature range: available on request.



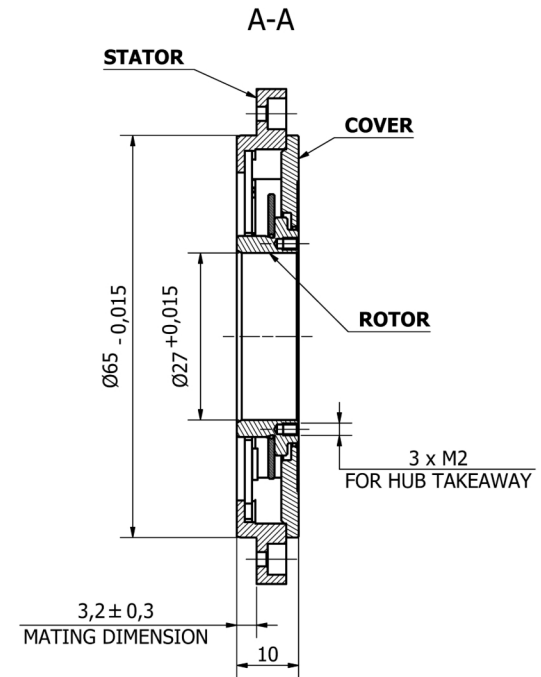
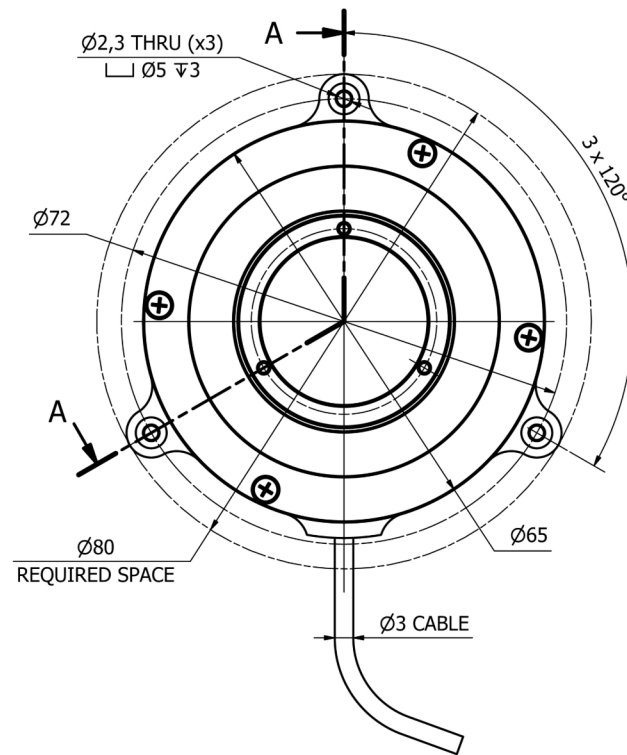

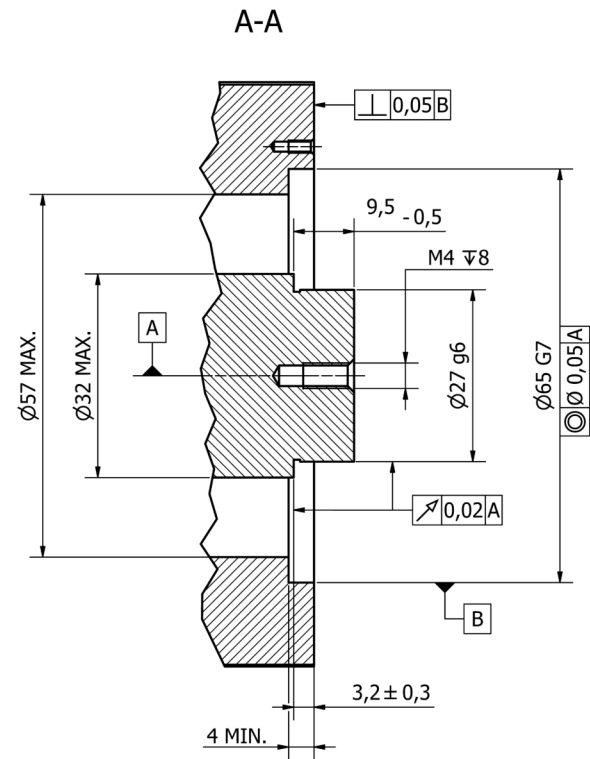
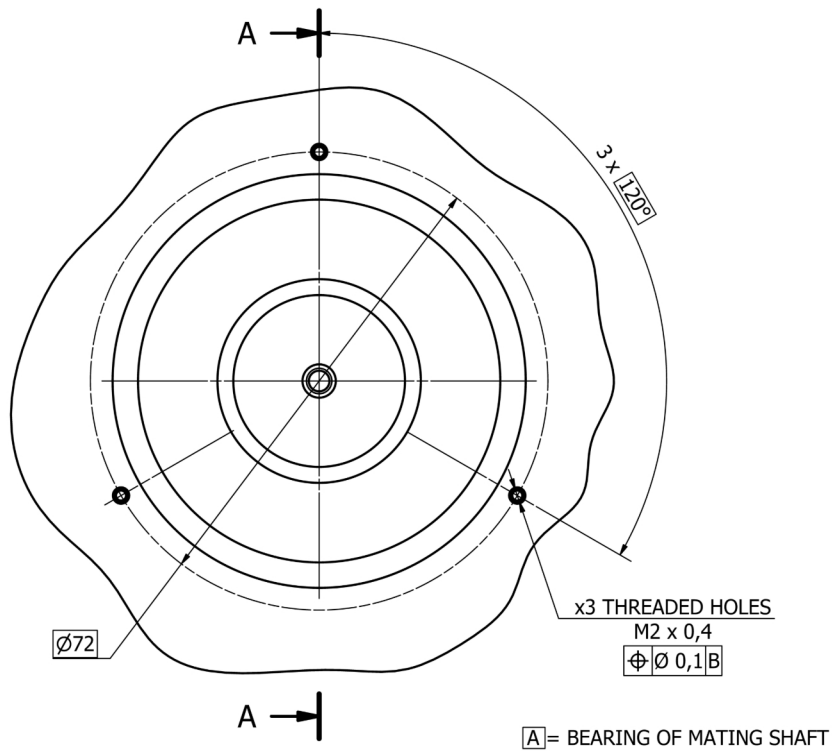

Mounting requirements

## Mounting

### (1) Stator

Place the sensor stator into  $\varnothing 65$  mm centering circumferential hole of the application. Align three equally spaced mounting holes ( $3 \times 120^\circ$ ) of the stator housing with the threaded holes (M2 x 0,4) of the application. Fasten with three screws (DIN 912 – M2 x 5). Recommended tightening torque  $Md = 0,3$  Nm.

### (2) Rotor

Ensure the disc of the Rotor (Disc/Hub assembly) is clean and free of damage.

Place the Rotor by using screw (DIN 912 – M4 x 8) and rotor pressing washer. Recommended tightening torque  $Md = 1,2$  Nm.

NOTE: in dynamic applications where high accelerations and mechanical vibrations are present, the use of thread locking adhesive is strongly recommended. (e.g. Loctite 242)

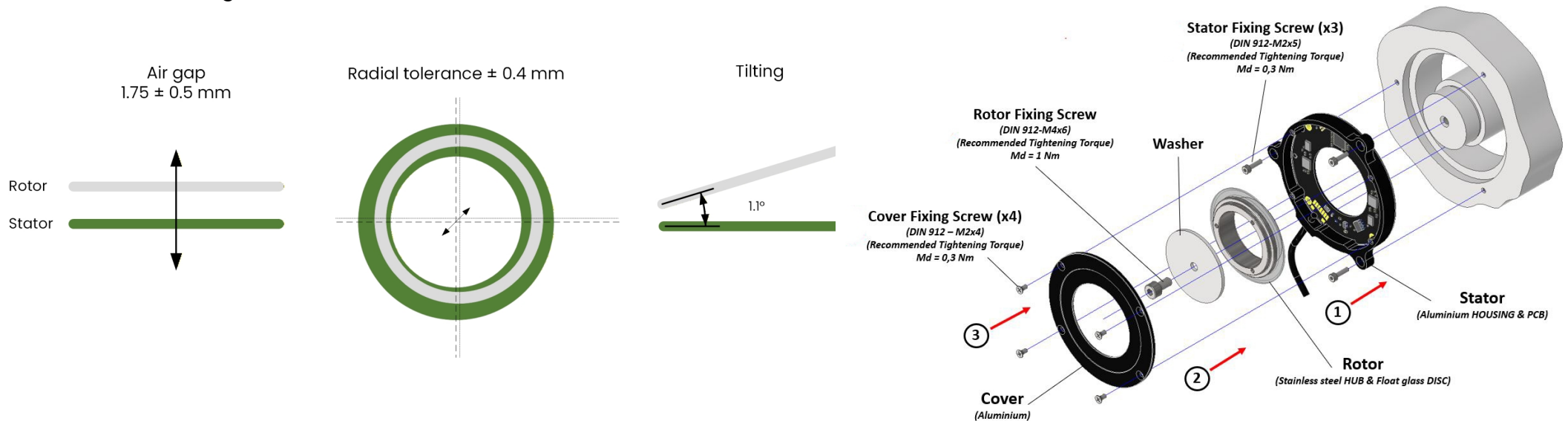

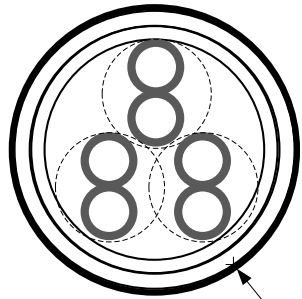

statum motion sensors support on-axis calibration for high-precision fine-tuning, though this level of adjustment is rarely required. Every sensor undergoes off-axis calibration during production as part of final quality assurance to validate overall performance and characteristics. Additional on-site configuration—such as rotation direction, zero-point setup, and more—is easily performed using the statum studio software tool.

### Interconnection



Ø 3.2 mm max

Cable	Twisted pair , Ø3.2 ± 0.15 mm
Wire	AWG 30 21/0.05 mm tinned copper Insulation - PFE Ø 0.6 ± 0.07 mm
Shield	Thinned copper braided 85%
Binder	FEB black
T. Rating	-40 / + 150 ° C

DB9	Function	Color	
6	Return	Black	
4	5 VDC	RED	
7	Data +	Green	
8	Data -	Yellow	
2	Clock +	Gray	
3	Clock -	Blue	
	Shield		

Absolute position protocols	
Output signals	EIA standard RS422
Data encoding	Binary
f : Clock frequency (max)	2.5 MHz

Description	Recommended
tp	Pause time > 21 µsec
tm	transfer time (monoflop time) = 20 µsec
BIT	Build In Test (MSB , Optional)

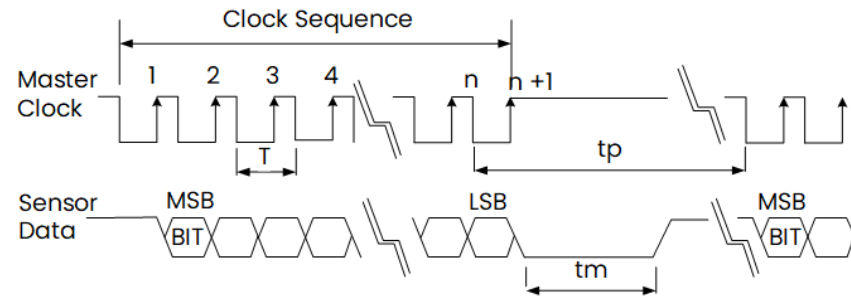

Description	Recommended
Error	Error bit – active low 1
Warn.	Warning bit – active low 1
CRC	CRC polynomial inverted 6

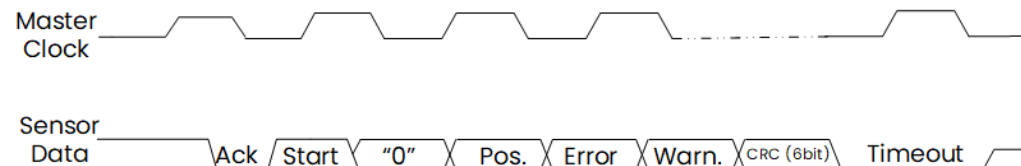

Sensor manufactured by statum motion are warranted to be free from defects in materials and workmanship for a period of 12 months from the date of shipment.

### Warranty Coverage

This warranty covers the replacement or repair of faulty encoders at no charge, provided that the following conditions are met:

- The sensor was installed, operated, and stored in accordance with the manufacturer's instructions.
- The sensor was not subjected to improper installation, misuse, or abuse.
- The sensor was not disassembled or repaired by the customer.

*Product specifications are subject to change without prior notice.*

*The product images shown are for illustration purposes only and may not be an exact representation of the product*

Ordering	<b>STD65</b>	a	b	c	d	e	f
----------	--------------	---	---	---	---	---	---

a	b	c	d	e	f
Resolution	Comm.	Cable	Length	Board	Custom
18-22	B – Biss C S – SSI	1 – Flying leads 2 – DB9 connector	1 – 250 mm 2 – 500 mm	1 – Standard 2 – Conformal coating	

Stator board protection	
PCB assemble	IPC 610 Class 3
PCB	IPC 620 Class 3
Sensor harness assembly	IPC-A 620 Class 3
Conformal coating (optional)	UVCL ; UV cure conformal coating IPC J-STD-001



statum motion LTD  
 5 Irus st', Afula Israel  
 +972 4 605 7195  
[info@statum-motion.com](mailto:info@statum-motion.com)