

STN-120

Absolute Position Sensor

The **STN-120** is a contact-less optical reflective absolute position sensor. It has Integrated dual sensing heads and advanced processing, which gives it a very high precision over a low profile and redundant core.

The **STN-120** support SSI & BiSS-C interfaces.

The wide assembly tolerance of the **STN-120** makes it easy to install and align, its plug and-play approach makes it simple to design into any application.

High precision single turn, optical reflective absolute position sensor

- Contact less
- Dual core, redundant - Duplus core technology
- Low profile
- High resolution
- High accuracy

Mechanical

OD stator	mm	120
ID rotor	mm	90
Height	mm	10
Rotor moment of inertia	kgm ²	< 2.5 x 10 ⁻⁴
Permissible radial run-out	mm	± 0.4
Rotor / Stator air gap	mm	1.75 ± 0.5
Weight	gr	120



Characteristic's

Resolution	bit	18 - 22
Accuracy [INL]	mdeg	± 4
Repeatability	count	± 1
Data latency	µsec	20
Startup time	msec	20
Current consumption	mA	130
Power supply	VDC	5 ± 5%
Rotation speed, max	RPM	4,000
Sensor position bandwidth	KHz	40 (SSI) / 65 (BiSS-C)
Thermal drift		None

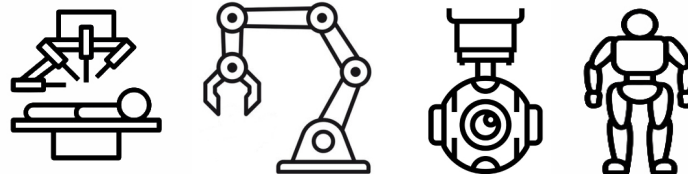

Environment Condition's

Temperature, operational	-40 to 85 C° ¹
Humidity	95% relative humidity, Non condensing, IEC 60068-2-78
IP rating	-
Shock	1000 m/s ² , 6 ms, ½ sine, 3 axes
Vibration	100 m/s ² max @ 55 Hz to 2000 Hz, 3 axes
Pressure	600 bar max
Vacuum	1.0 × 10 ⁻⁷ Pa
Magnetic field	Immune
EMC compliance	IEC 61326-1
Environmental compliance	RoHS, REACH

Storage and Handling



Stator is ESD-sensitive and must be handled with care.

Avoid touching the electronic circuitry, wiring, or sensor surfaces unless you are using proper ESD protection and are within an ESD-controlled environment.

Storage Condition's

Temperature, Storage	-45 to 105 C°
Humidity	70 % relative humidity, Non condensing,

Notes :

¹ Extended temperature range: available on request.



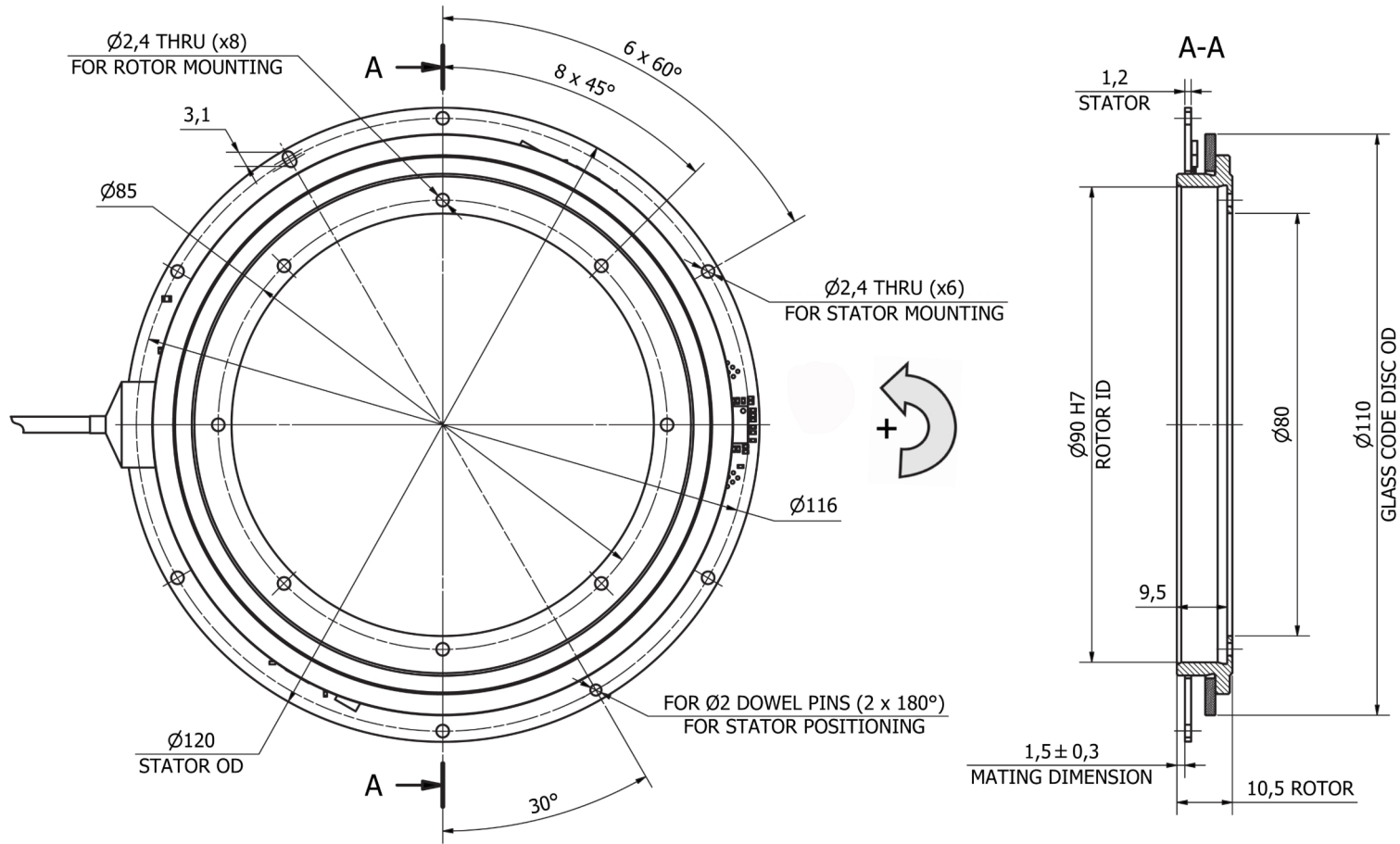

Mounting

(1) Stator

Place the Stator of the encoder onto the support of the application. Use two M2 dowel pins for correct positioning. Fasten with six screws (DIN 912 - M2 x 5). Recommended tightening torque $M_d = 0,15 \text{ Nm}$.

(2) Rotor

Ensure the disc of the Rotor (Disc/Hub assembly) is clean and free of damage.

Place the Rotor by using screw (DIN 912 - M4 x 8) and rotor pressing washer. Recommended tightening torque $M_d = 1,2 \text{ Nm}$.

NOTE: in dynamic applications where high accelerations and mechanical vibrations are present, the use of thread locking adhesive is strongly recommended. (e.g. Loctite 242)

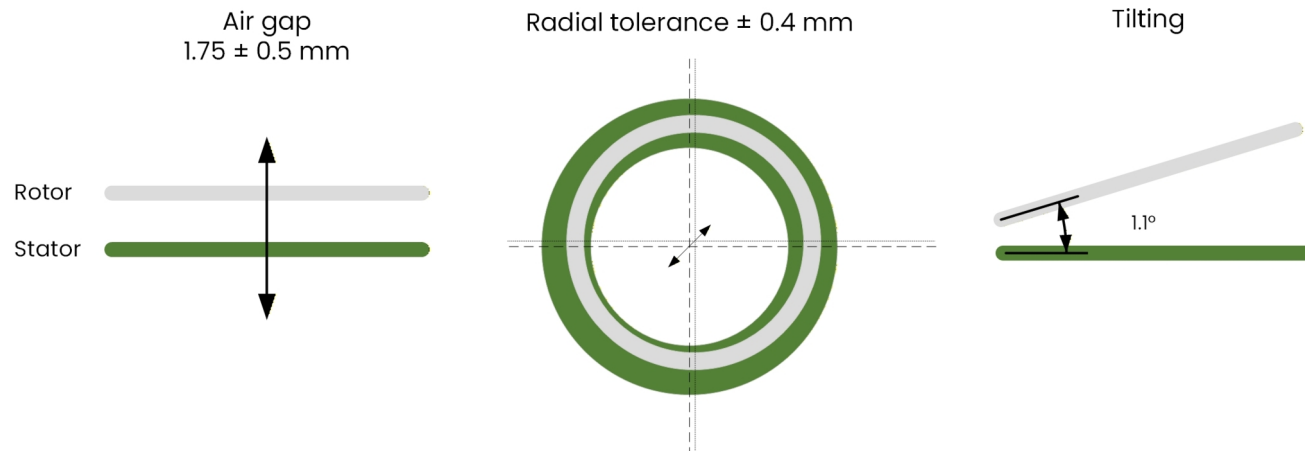

statum motion sensors support on-axis calibration for high-precision fine-tuning, though this level of adjustment is rarely required. Every sensor undergoes off-axis calibration during production as part of final quality assurance to validate overall performance and characteristics. Additional on-site configuration—such as rotation direction, zero-point setup, and more—is easily performed using the statum studio software tool.



Interconnection

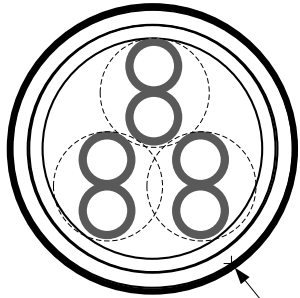

Ø 3.2 mm max

Cable	Twisted pair , Ø3.2 ± 0.15 mm
Wire	AWG 30 21/0.05 mm tinned copper Insulation - PFE Ø 0.6 ± 0.07 mm
Shield	Thinned copper braided 85%
Binder	FEB black
T. Rating	-40 / + 150 ° C

DB9	Function	Color	
6	Return	Black	⊗
4	5 VDC	RED	
7	Data +	Green	⊗
8	Data -	Yellow	
2	Clock +	Gray	⊗
3	Clock -	Blue	
	Shield		

Absolute position protocols

Output signals	EIA standard RS422
Data encoding	Binary
f : Clock frequency (max)	2.5 MHz

Description	Recommended
tp	Pause time > 21 µsec
tm	transfer time (monoflop time) = 20 µsec
BIT	Build In Test (MSB , Optional)

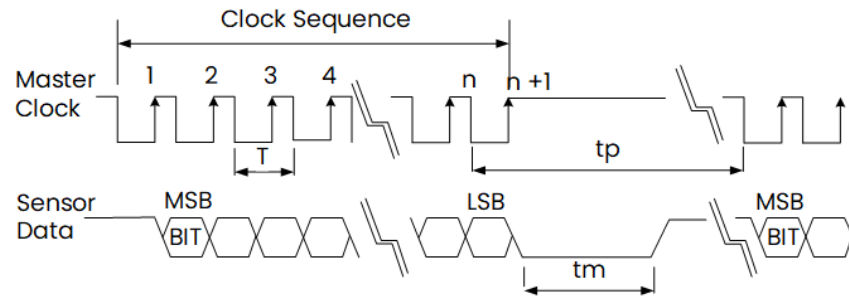

Description	Recommended
Error	Error bit – active low 1
Warn.	Warning bit – active low 1
CRC	CRC polynomial inverted 6

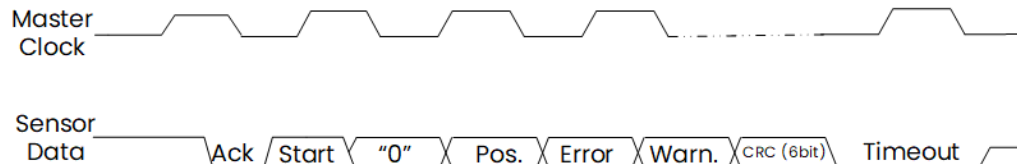

Sensor manufactured by statum motion are warranted to be free from defects in materials and workmanship for a period of 12 months from the date of shipment.

Warranty Coverage

This warranty covers the replacement or repair of faulty encoders at no charge, provided that the following conditions are met:

- The sensor was installed, operated, and stored in accordance with the manufacturer's instructions.
- The sensor was not subjected to improper installation, misuse, or abuse.
- The sensor was not disassembled or repaired by the customer.

*Product specifications are subject to change without prior notice.
The product images shown are for illustration purposes only and may not be an exact representation of the product*

Ordering	STN120	a	b	c	d	e	f
----------	---------------	---	---	---	---	---	---

a	b	c	d	e	f
Resolution	Comm.	Cable	Length	Board	Custom
18-22	B – Biss C S – SSI	1 – Flying leads 2 – DB9 connector	1 – 250 mm 2 – 500 mm	1 – Standard 2 – Conformal coating	

Stator board protection	
PCB assemble	IPC 610 Class 3
PCB	IPC 620 Class 3
Sensor harness assembly	IPC-A 620 Class 3
Conformal coating (optional)	UVCL ; UV cure conformal coating IPC J-STD-001



statum motion LTD
5 Irus st', Afula Israel
+972 4 605 7195
info@statum-motion.com